



MODEL TBCCT-XXX

50, 100, 150, 200, OR 300

COMBINATION BATCH COOK-CHILL TANK

GENERAL DESCRIPTION

The TUCS BATCH COOK-CHILL TANK is a multipurpose machine to quickly chill packaged hot liquids and/or automatically cook and chill vacuum packaged non pumpable products. The machine is equipped with an integral chilled water generator coupled to a remote refrigeration compressor thereby eliminating bulky problematic ice builders, falling film chillers or chilled glycol systems. The design incorporates a tank "floor" which rises to bring chilled pouches and casings out of the chill water for easy removal. The floor can also be lowered and raised incrementally for the easy loading and unloading of products for cook tank processing thereby eliminating the necessity for expensive, space consuming hoist monorail systems or jib style cranes.



Tucs Model TBCCT shown with optional chart recorder

CERTIFICATIONS

ANSI/UL-197, ANSI/UL-471



TUCS Equipment, Inc.

755 County Road 18 S. • Princeton MN 55371

Phone 763-574-7475 Fax 763-574-7472

www.tucsequipment.com

ITEM NO.

PROJECT

QUANTITY

AIA NO.

CAPACITIES

Available in 50, 100, 150, 200- and 300-gallons nominal batch chill capacities up to 500, 1000, 1500, 2000 and 3,000 lbs. nominal cook tank capacities respectively

CONSTRUCTION & FEATURES

304L stainless steel tank mounted on adjustable legs with leg pads ■ Hinged, powered, lockable cover ■ Insulated tank wall and floor with urethane foam to prevent sweating and condensation ■ Heating via steam coil rated at up to 150 psi steam. Operates dependably at pressure down to 15 psi ■ Push button raising and lowering of open grid floor for easy removal of cooled product and for easy loading of product to be cooked ■ High volume air pump agitation of tank water for effective and gentle tumble chilling ■ Removable racks with 17 angle guides and 7 wire shelves (standard) for holding product when in cook mode ■ Does not require ventilation hood in most locations (check local code)

AIR AGITATION

$\frac{3}{4}$ to 1 HP high volume, low pressure air pump ■ Dual, interconnected stainless steel air bubbler lines running full length of tank ■ Mounted and prewired to control

COOLING EVAPORATORS

Stainless steel evaporator coils designed for Freon or ammonia refrigerant ■ Evaporator coils easy to view and clean

CONTROLS

Programmable Logic Controller (PLC) contained within NEMA 4X control box ■ Touch screen operator interface with menu driven operation ■ Batch chill mode ■ Display of process water temperature ■ Display of process time ■ Cook-Chill mode ■ Mode selection: cook to time, cook to probe temperature ■ Digital input and display of process water temperature, product temperature (probe) cook time ■ Includes 100 probe seals ■ Electronic temperature recording

OPTIONS

- Electronic Data Logger
- Chilled water take off heat exchanger with pump to provide chilled water for other purposes such as kettle jacket cooling
- Tank divider for separating tumble chill batches
- Dial up alarm system
- Air or water-cooled remote compressor/condensers for evaporator coils (includes DX coils and solenoid)

MODEL TEBCCT-XXX

50, 100, 150, 200, OR 300
COMBINATION BATCH COOK-CHILL TANK

Scan this QR code with your smart phone to visit our website for more information.

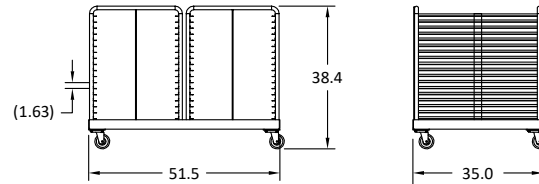
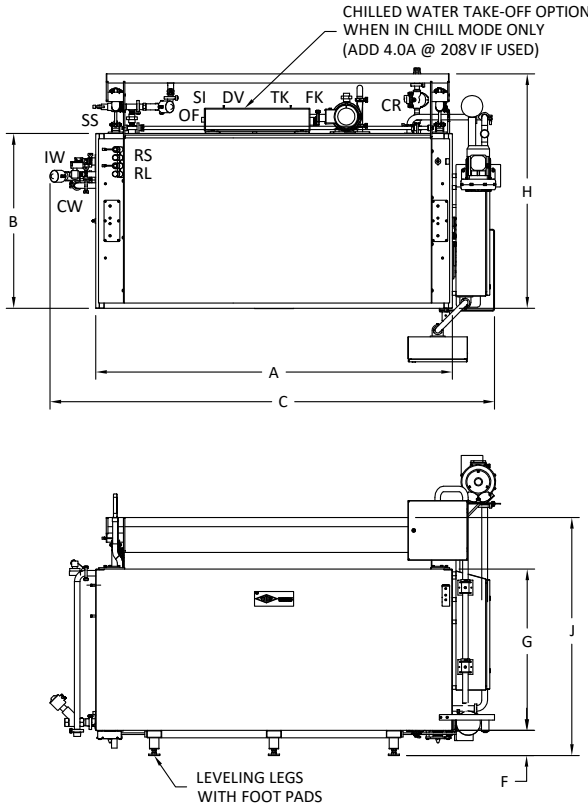

SINGLE DOLLY W/TWO SHELVING RACKS

1 SHELVING RACK FOR EACH 50 GALLONS OF TANK PRODUCT CAPACITY
17 SHELVES WITH 1.05" BETWEEN EACH SHELF

3/4 HP BLOWER FOR AGITATION CAN BE MOUNTED ABOVE THE CEILING ACOUSTICAL TILES TO REDUCE NOISE

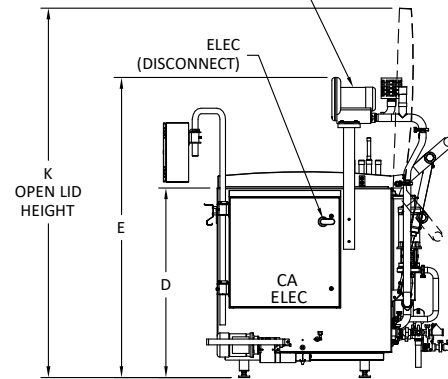

- NOTES:
1. SHOWN WITH CONTROL ON RIGHT SIDE. LEFT SIDE AVAILABLE.
 2. DIMENSIONS SUBJECT TO CHANGE WITHOUT NOTICE - CHECK WITH FACTORY.
 3. ALLOW 36" MINIMUM CLEARANCE IN FRONT OF CONTROL PANEL.
 4. REFRIGERATION CONNECTION SIZES SHOWN ARE TYPICAL FROM FACTORY. ALTERNATE CONNECTION SIZES ARE AVAILABLE UPON REQUEST.
 5. 3" FLEXIBLE HOSE CONNECTIONS INCLUDED FOR CA, SS, CR, AND PW. INSTALLER MUST PROVIDE STAINLESS ELBOWS OR STREET ELBOWS WHEN MAKING FINAL CONNECTIONS.
 6. TYPICAL REFRIGERATION COIL QUANTITIES SHOWN MAY CHANGE TO ACCOMMODATE REFRIGERANT SUPPLY.
 7. CUSTOMER TO PROVIDE REGULATED WATER PRESSURE NOT TO EXCEED 100 PSI.

DIMENSIONS

SIZE	A	B	C	D	E	F	G	H	J	K
50	48	47	72	51	81	7	44	64	65	100
100	71	47	96	51	81	7	44	64	65	100
150	96	47	120	51	81	7	44	64	65	100
200	120	47	144	51	81	7	44	64	65	100
300	174	47	198	51	81	7	44	64	65	100

COMMON UTILITY CONNECTIONS

SIZE	COMPR. AIR 10 CFM @ 90 PSI	STEAM	COND. RETURN	COLD POTABLE WATER @ 100 PSI MAX	HOT POTABLE WATER @ 100 PSI MAX (OPTIONAL)	INDIRECT WASTE	OVERFLOW	ELECTRIC (OPTIONS)			OPTIONAL CHILLED WATER TAKE-OFF				
								@ 208V	@ 240V	@ 480V	SUPPLY IN	FROM KETTLES	TO KETTLES	OVERFLOW	DRAIN VALVE
CAPACITY	CA	SS	CR	CW	HW	IW	OV	ELEC	ELEC	ELEC	SI	FK	TK	OF	DV
50-300	3/4" QD	1" NPT	1" NPT	3/4" NPT	3/4" NPT	2" NPT	1 1/2" NPT	9.1A	8.0A	4.0A	3/4" NPT	1 1/2" NPT	1 1/2" NPT	3/4" NPT	1/2" NPT

UTILITY REQUIREMENTS

SIZE		STEAM SUPPLY (150 psi MAX)	REFRIGERATION				WEIGHT (LBS)	
PRODUCT CAPACITY (GALLONS)	SOLID MUSCLE POUNDS		LBS/HR MAX @ 45 PSI	* COIL QUANTITY PER UNIT	TOTAL BTU/hr @ 25°F SUCTION	LIQUID	SUCTION	EMPTY
50	400-500	350	1	70,000	5/8"	1 3/8"	1,030	3,630
100	800-1,000	600	1	120,000	5/8"	1 3/8"	1,480	5,590
150	1,200-1,500	850	1	145,000	7/8"	1 3/8"	2,580	7,980
150	1,200-1,500	850	2	145,000	5/8"	1 3/8"	2,580	7,980
200	1,600-2,000	1,200	2	230,000	5/8"	1 3/8"	2,880	9,630
300	2,400-3,000	1,800	2	336,000	7/8"	2 1/8"	4,180	14,030
300	2,400-3,000	1,800	3	336,000	5/8"	1 3/8"	4,180	14,030

RECOMMENDED CLEARANCES

RIGHT HAND TANK	
RIGHT (PANEL) SIDE	36"
BACK SIDE	36"
LEFT SIDE	18"